

II. 2017 Trial Evolutions

125 / 250 / 300 ST 2T 2017:



II. 2017 Trial Evolutions



125 / 250 / 300 ST Common evolutions

- ❑ New steering stops
 - Frame protected against crushing

- ❑ New lower chain frame guard
 - Pad life improved

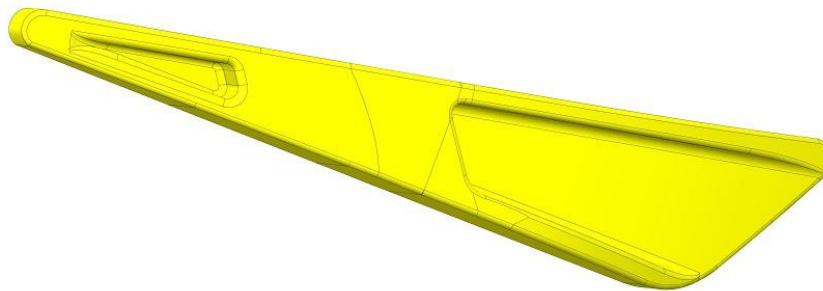

II. 2017 Trial Evolutions



125 / 250 / 300 ST Common evolutions

- ❑ **New front brake master cylinder**
 - **Better feeling and information feedback**

- ❑ **Dual ignition system**
 - **Combustion stability improved**
 - **Less sensibility to carb settings (reduced influence of altitude and weather conditions)**
 - **identical ignition to factory version**



II. 2017 Trial Evolutions



125 / 250 / 300 ST 2T Common evolutions

- ❑ New Clutch : diaphragm system 100 % Sherco technology

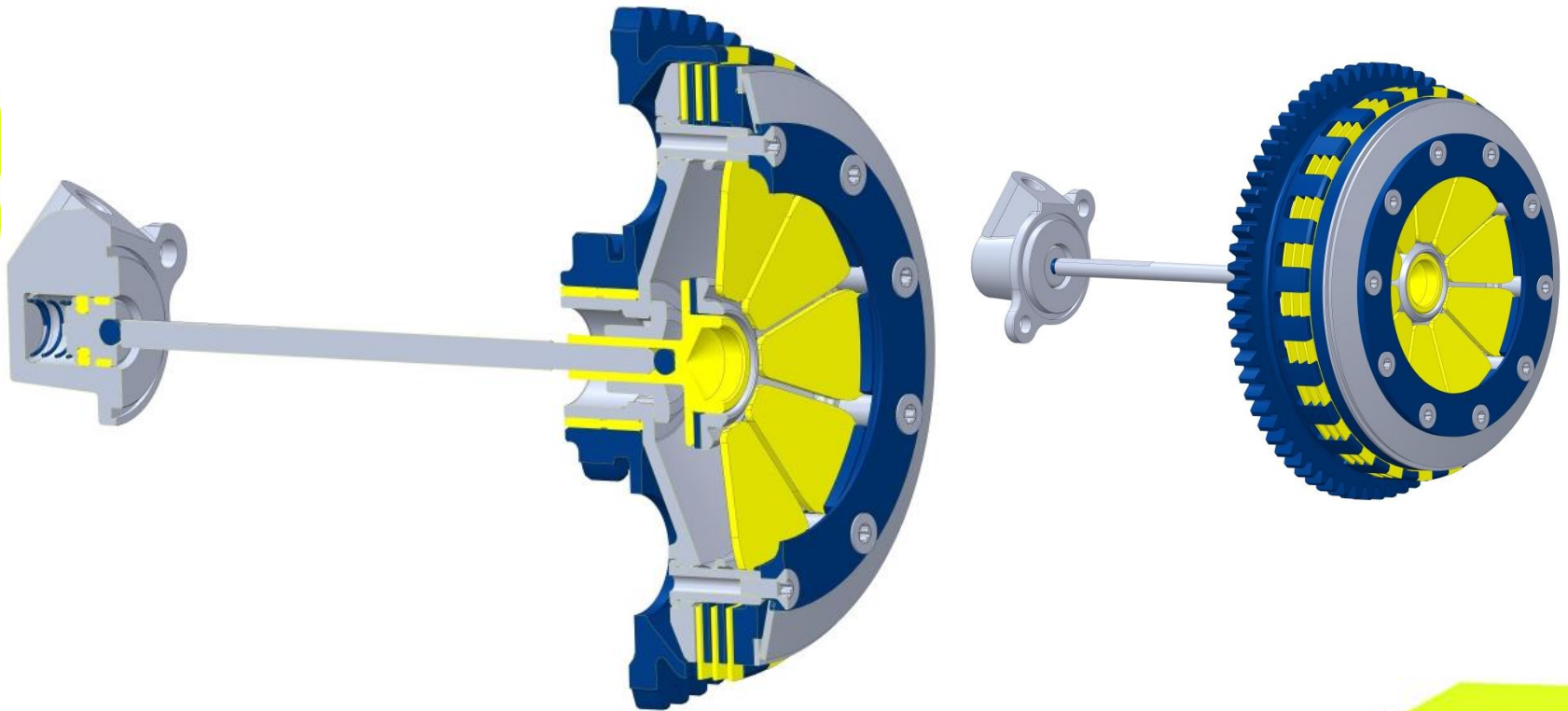

- *Progressive control*
- *Better feeling*
- *Top riders better performance*

II. 2017 Trial Evolutions



125 / 250 / 300 ST 2T Common evolutions

- ❑ New Clutch : diaphragm system (2)

	2017 (NEW)
SYSTEM	Diaphragm system
Progressivity	Progressive clutch disengagement
Temperature influence	Stable feeling with temperature variations
Precision control	Optimized connection friction point / lever
Clutch disengagement	Disengagement 100% efficient even with high RPM Security improved
Compacity	Reduction: diameter -18mm wideness: -13mm 3 friction discs

- ❑ New clutch master cylinder: more precise sensibility